

# Grinn AstraEVB-1680 User Guide

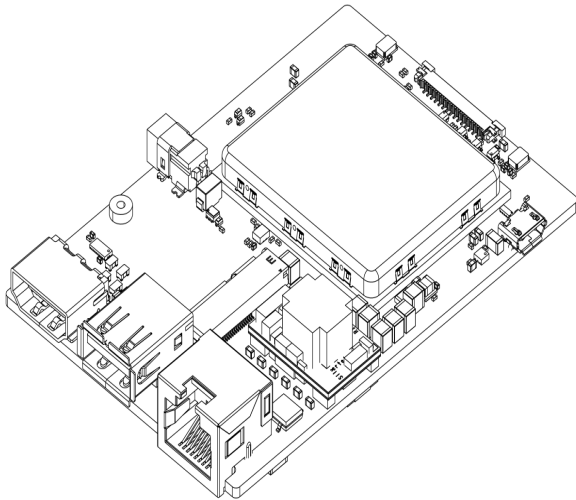

## 1 Features

- fast time to market
- small PCB dimensions: 61.6mm x 91.1mm
- one micro USB cable and USB-UART converter is needed to program AstraEVB
- single power supply unit with 0.7mm/2.35mm DC jack
- 1x micro USB OTG port
- 1x UART port
- 1x built-in USB interface
- 10/100/1000M Ethernet PHY(RGMII)
- 2x MEMS microphones
- high precision and ultra-low-power pulsed coherent radar
- 2x IR diodes with Buck-Boost LED Driver
- 4x general purpose LEDs
- 1x general purpose Button
- 1x HDMI port
- 3x camera connectors
- 2x camera interfaces
- 1x M.2.E connector
- power over Ethernet (PoE) support

## 2 Applications

- AI-supported computer vision applications
- Advanced IoT devices
- Smart home applications
- Industrial automation
- Streaming audio and video
- Multimedia applications

## 3 Description

The Grinn AstraEVB-1680 is a comprehensive hardware platform, ideal for exploring the capabilities of

the Grinn AstraSOM-1680 module. Tailored for computer vision and AI applications, the board includes multiple camera slots that provide flexible and powerful imaging options. These slots allow developers to integrate and experiment with camera configurations such as stereo camera setup, which enable depth perception, object tracking, and 3D modeling—essential for advanced applications such as autonomous navigation, facial recognition, and AR/VR experiences.

Each camera interface supports high-resolution sensors, ensuring that captured images and video are detailed and clear. This makes it suitable for applications that rely on high-quality visuals, such as quality inspection, surveillance, and robotics. Combined with the two powerful infrared (IR) diodes, the board's cameras can capture images even in low-light or nighttime conditions, enhancing usability for security, wildlife monitoring, and night-vision applications.

Additionally, the board's flexible design allows for easy customization of the camera configuration to suit specific project needs. Whether developers are working on single-camera setups or complex multi-camera systems, the Grinn AstraEVB-1680 provides a reliable platform to test and refine computer vision applications in diverse lighting environments and conditions.

Grinn AstraEVB-1680 can be also used as a reference for designing schematics and PCB layouts for a customer's new product.

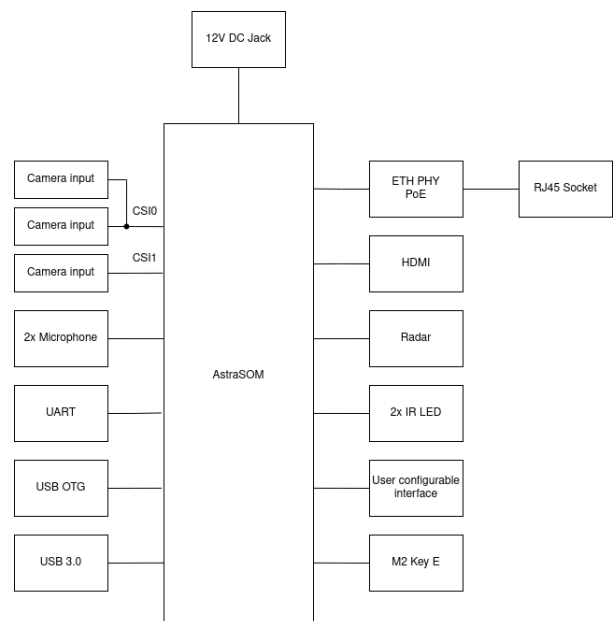

Figure 1: Functional block diagram

## Contents

<b>1</b>	<b>Features</b>	<b>1</b>
<b>2</b>	<b>Applications</b>	<b>1</b>
<b>3</b>	<b>Description</b>	<b>1</b>
<b>4</b>	<b>Revision History</b>	<b>3</b>
<b>5</b>	<b>Functional Description</b>	<b>4</b>
5.1	Power supply . . . . .	4
5.2	Debug port . . . . .	5
5.3	Video Interfaces . . . . .	6
5.3.1	HDMI . . . . .	6
5.3.2	Video Input . . . . .	6
5.4	Audio Interfaces . . . . .	8
5.5	M.2 Interface . . . . .	10
5.6	Ethernet . . . . .	13
5.7	USB . . . . .	14
5.8	Radar . . . . .	15
5.9	IR diodes . . . . .	16
5.10	User-Configurable interfaces . . . . .	17
<b>6</b>	<b>Boot options</b>	<b>18</b>
6.1	Supported OS . . . . .	18
6.2	Flashing . . . . .	18
<b>7</b>	<b>Electrical Characteristics</b>	<b>19</b>
7.1	Absolute Maximum Ratings . . . . .	19

## 4 Revision History

---

Revision	Date	Changes
1.0	26.11.2024	Initial revision.

---

## 5 Functional Description

### 5.1 Power supply

The Grinn AstraEVB-1680 board offers flexible power options, allowing it to be supplied either through a 12V DC jack or via Power over Ethernet (PoE). This dual power setup provides versatility, making it suitable for installations where direct power access might be limited. The DC jack option is ideal for setups with a dedicated power source, while PoE enables both power and data transmission over a single Ethernet cable, reducing cable clutter and simplifying deployment. However, as PoE provides up to 10W of power, it may not meet the needs of applications with high power demands. With these options, the Grinn AstraEVB-1680 board can be used in a range of environments, from traditional powered settings to network-based installations, like security systems or IoT applications.

Power Supply Diagram

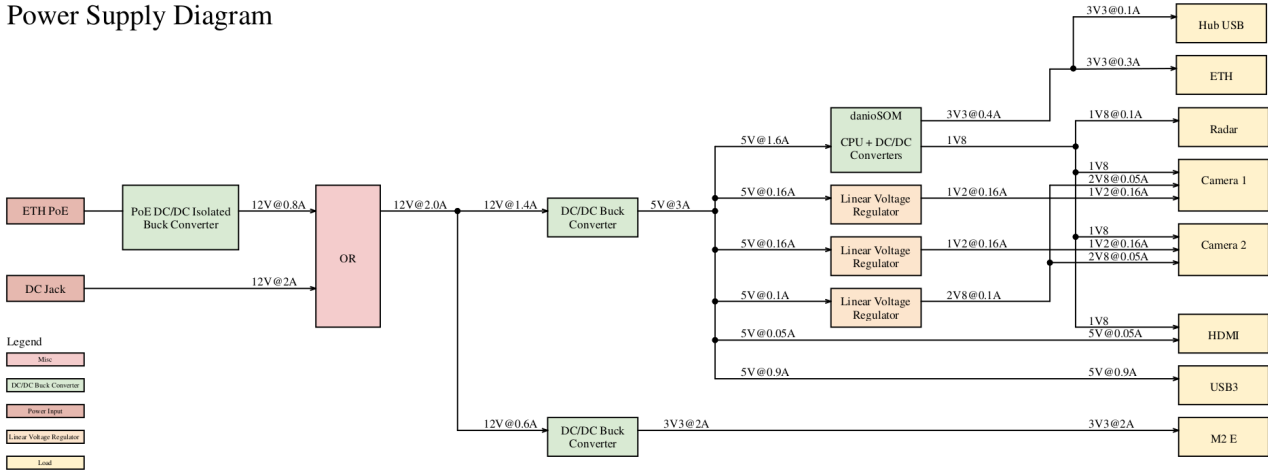

Figure 2: Power block diagram

The table below illustrates the relationship between the control signal and the domain it controls. If a domain is not listed, it is always enabled.

Table 1: Control signal to controlled domain mapping

CPU pin	Pin name	Schematic signal	Switchable domains
R55	STS1_SOP	HDMI_TX_5V_EN	5V
W53	USB2_DRV_VBUS	USB2_EN	USB2_VBUS
L47	SDIO_WP	USB3_EN	USB3_VBUS

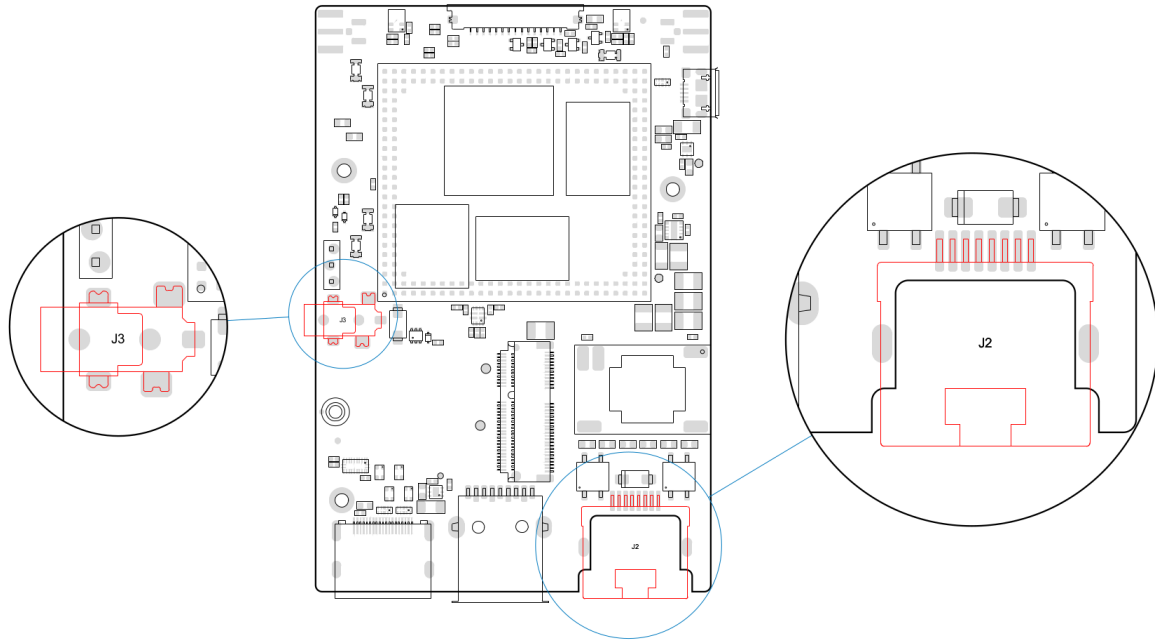

Figure 3: Power input options

## 5.2 Debug port

The Grinn AstraEVB-1680 board features a UART port designed to operate with 1.8V signal levels, making it ideal for low-power devices. This versatile port supports both firmware flashing and debugging, providing a reliable interface for development tasks. Its 1.8V tolerance ensures seamless integration with embedded systems where voltage compatibility is essential. However, caution is required, as connecting devices with higher voltage levels can damage the board’s circuitry. To avoid issues, users should ensure proper voltage matching and consider level shifters or regulators when necessary. These precautions help maintain the board’s performance and longevity.



The debug pins are 1.8V tolerant. Using higher voltages can permanently damage the board.

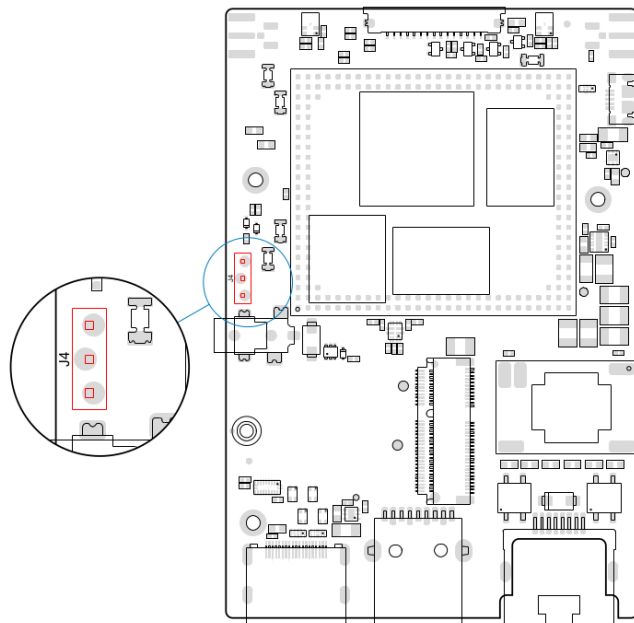

Figure 4: Debug port

### 5.3 Video Interfaces

#### 5.3.1 HDMI

The Grinn AstraEVB-1680 board is equipped with an HDMI port, supporting the 2.0b standard for high-definition display output. This allows the board to easily connect to monitors, TVs, or projectors, making it suitable for applications like media playback, digital displays, or interactive interfaces. With HDMI, users can enjoy clear visuals and reliable video performance, enhancing the board’s capabilities for multimedia applications.

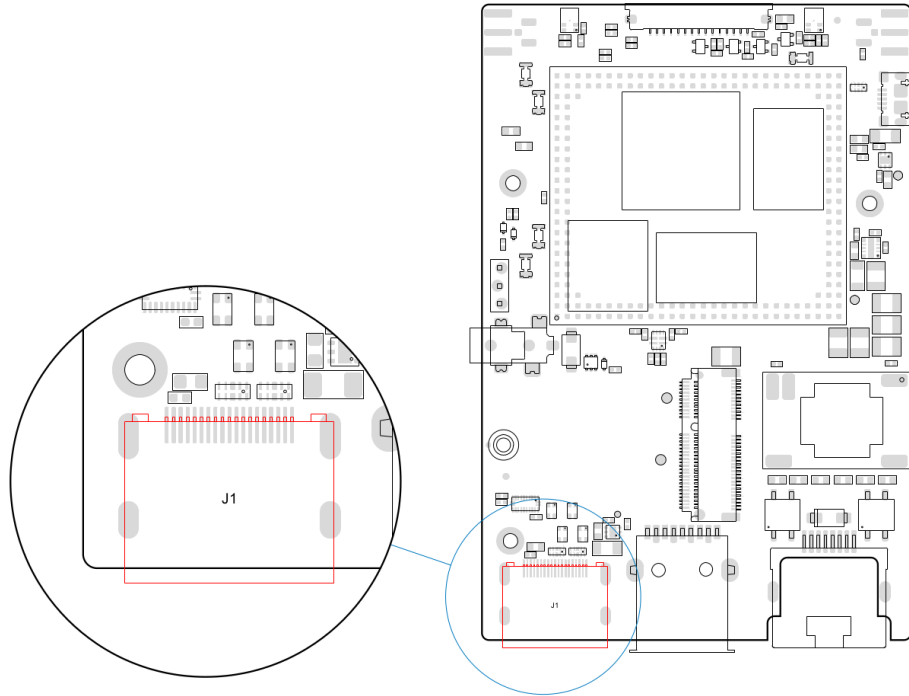

Figure 5: HDMI connector

#### 5.3.2 Video Input

The Grinn AstraEVB-1680 is equipped with three 2-lane Camera Serial Interface (CSI) ports, enabling high-speed data transmission between the device’s camera modules and processor. However, only two of these interfaces can be utilized simultaneously due to design constraints.

CSI-0: This interface offers flexible connectivity options and can be accessed either through a 15-pin ZIF connector or a 30-pin, 2-row board-to-FPC straight connector.

CSI-1: This interface, in contrast, is exclusively available through the 30-pin, 2-row board-to-FPC straight connector, providing a stable connection for integrated setups.

The CSI interfaces on the Grinn AstraEVB-1680 are designed to support high-resolution camera modules, making them suitable for applications that require robust image capture capabilities, such as computer vision, AI-based imaging, and multimedia processing.

Table 2: Connectors identifier

-	CSI0 (J6)	CSI0 (J10)	CSI1 (J7)
NPM	DF37NC-30DS-0.4V(51)	686115183422	DF37NC-30DS-0.4V(51)

Table 3: CSI connectors pinout

Pin	CSI0 (J6)	CSI0 (J10)	CSI1 (J7)
1	NC	3V3	NC
2	TW0.SDA	TW0.SDA	SM.TW2.SDA
3	NC	TW0.SCL	NC
4	TW0.SCL	LED.ENn	SM.TW2.SCL
5	1V8	PWR.ENn	1V8
6	GND	GND	GND
7	CSI0.1V2	MIPLCSI0.CKp	CSI1.1V2
8	MIPLCSI0.CKp	MIPLCSI0.CKn	MIPLCSI1.CKp
9	1V8	GND	1V8
10	MIPLCSI0.CKn	MIPLCSI0.D1p	MIPLCSI1.CKn
11	GND	MIPLCSI0.D1n	GND
12	GND	GND	GND
13	24MHz	MIPLCSI0.D0p	24MHz
14	MIPLCSI0.D0p	MIPLCSI0.D0n	MIPLCSI1.D0p
15	GND	GND	GND
16	MIPLCSI0.D0n		MIPLCSI1.D0n
17	GND		GND
18	GND		GND
19	2V8		2V8
20	MIPLCSI0.D1p		MIPLCSI1.D1p
21	NC		NC
22	MIPLCSI0.D1n		MIPLCSI1.D1n
23	GND		GND
24	GND		GND
25	NC		NC
26	NC		NC
27	NC		NC
28	NC		NC
29	GND		GND
30	GND		GND

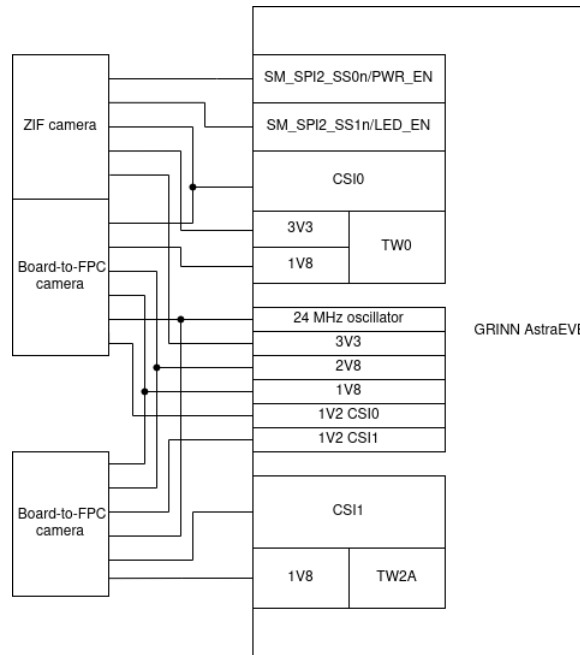

Figure 6: Video input diagram

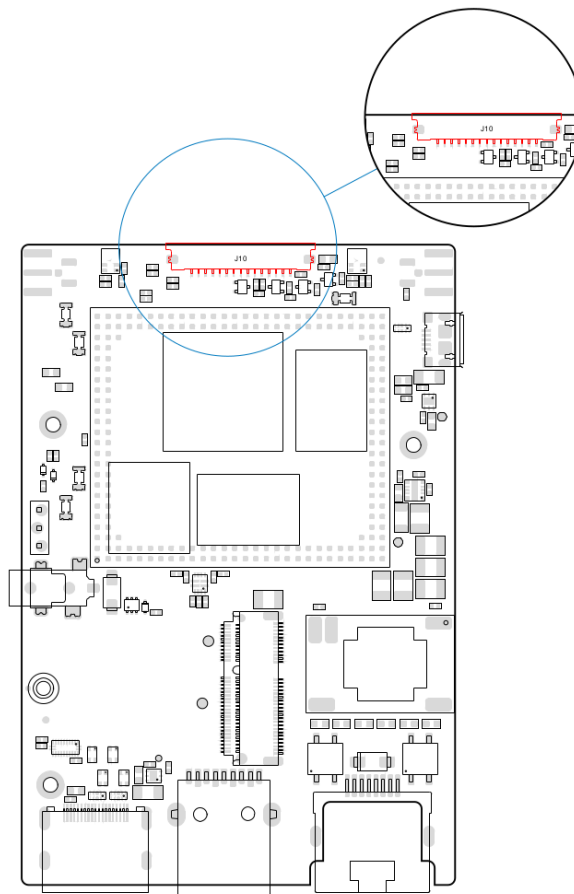

Figure 7: Camera connectors placement front

### 5.4 Audio Interfaces

The Grinn AstraEVB-1680 board features two microphones connected via the PDM (Pulse Density Modulation) interface, utilizing SPH0655LM4H-1 MEMS microphones. These microphones are designed to capture high-quality audio with low noise, making them ideal for voice and sound detection applications. The PDM interface enables direct digital output, eliminating the need for an analog-to-digital converter and ensuring clear, noise-



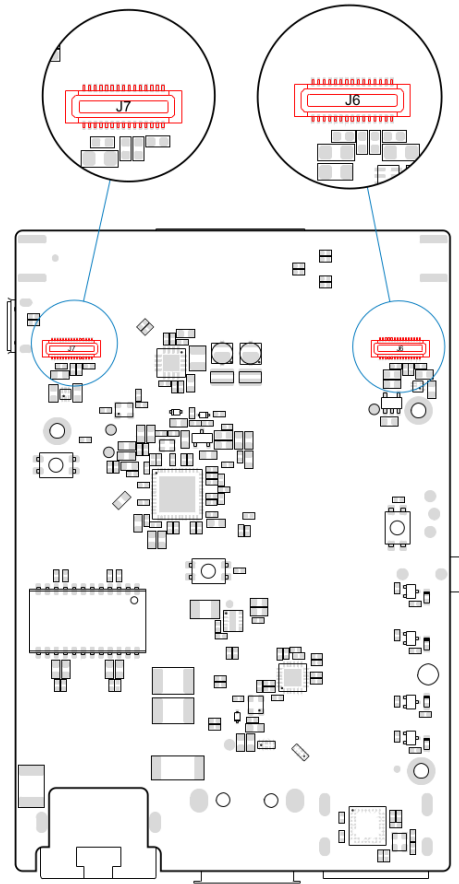

Figure 8: Camera connectors placement back

resistant audio data transmission. With their compact design and low power consumption, these microphones are well-suited for portable and embedded systems. The integration of two microphones provides stereo or directional sound capture, enhancing the board’s capabilities for advanced audio processing tasks.

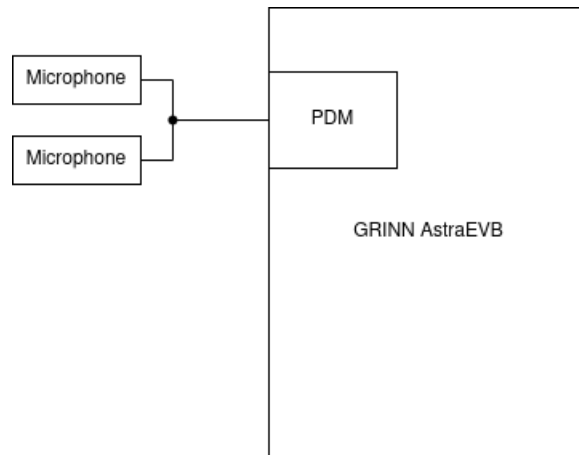

Figure 9: Audio diagram

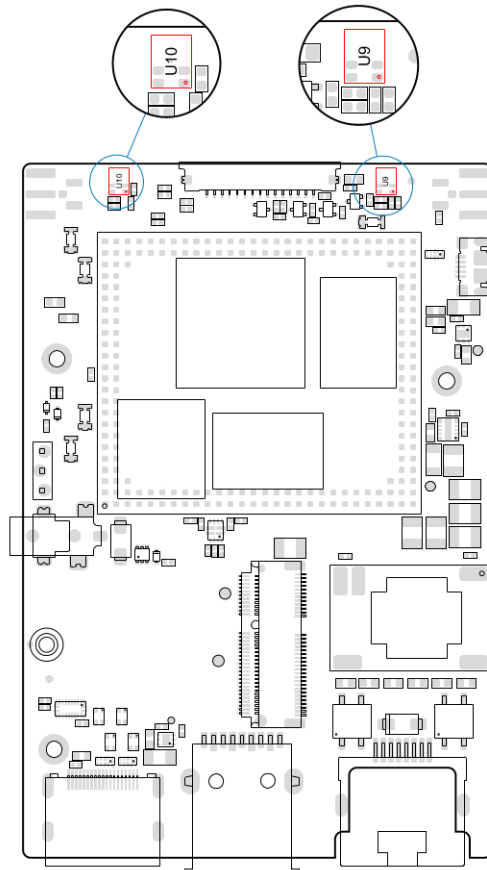

Figure 10: MEMS microphones

## 5.5 M.2 Interface

The Grinn AstraEVB-1680 board comes equipped with a versatile M.2 slot, inviting users to expand its capabilities in unique ways—whether by adding WiFi/BLE connectivity (such as the AP12275.M2P module) or supercharging AI processing with the Hailo-8 A+E accelerator or leveraging support for M.2 22x30 (2230) modules, providing enhanced versatility and accommodating a broader range of expansion options. With options for wireless communication or dedicated neural processing, this slot opens up possibilities for edge applications that require powerful, on-device computation, such as real-time image analysis or data-intensive tasks. This flexibility transforms the Grinn AstraEVB-1680 board into a customizable platform, ready to tackle applications from IoT to advanced machine learning at the edge.

Table 4: M2 Key E slot pinout

Pin	Pin name
1	GND
2	3V3_M2
3	USB2_D_P
4	3V3_M2
5	USB2_D_N
6	NC
7	GND
8	PCM_BCLK
9	SDIO_CLK
10	PCM_LRCLK
11	SDIO_CMD
12	PCM_DI
13	SDIO_DATA0
14	PCM_D0

Pin	Pin name
15	SDIO_DATA1
16	TP3
17	SDIO_DATA2
18	GND
19	SDIO_DATA3
20	BT_HOST_WAKE
21	NC
22	UART_RXD
23	NC
32	UART_TXD
33	GND
34	UART_CTS <sub>n</sub>
35	PCIE_TX0.C_P
36	UART_RTS <sub>n</sub>
37	PCIE_TX0.C_N
38	BT_DEV_WAKE
39	GND
40	WL_HOST_WAKE
41	PCIE_RX0.C_P
42	NC
43	PCIE_RX0.C_N
44	NC
45	GND
46	NC
47	PCIE_CLK_P
48	NC
49	PCIE_CLK_N
50	NC
51	GND
52	PCIE_RST <sub>n</sub>
53	PCIE_CLKREQ <sub>n</sub>
54	BT_REG_ON
55	PCIE_WAKE <sub>n</sub>
56	WL_REG_ON
57	GND
58	NC
59	PCIE_TX1.C_P
60	NC
61	PCIE_TX1.C_N
62	NC
63	GND
64	NC
65	PCIE_RX1.C_P
66	NC
67	PCIE_RX1.C_N
68	NC
69	GND
70	NC
71	NC
72	3V3_M2
73	NC
74	3V3_M2
75	GND

Pin	Pin name
76	GND

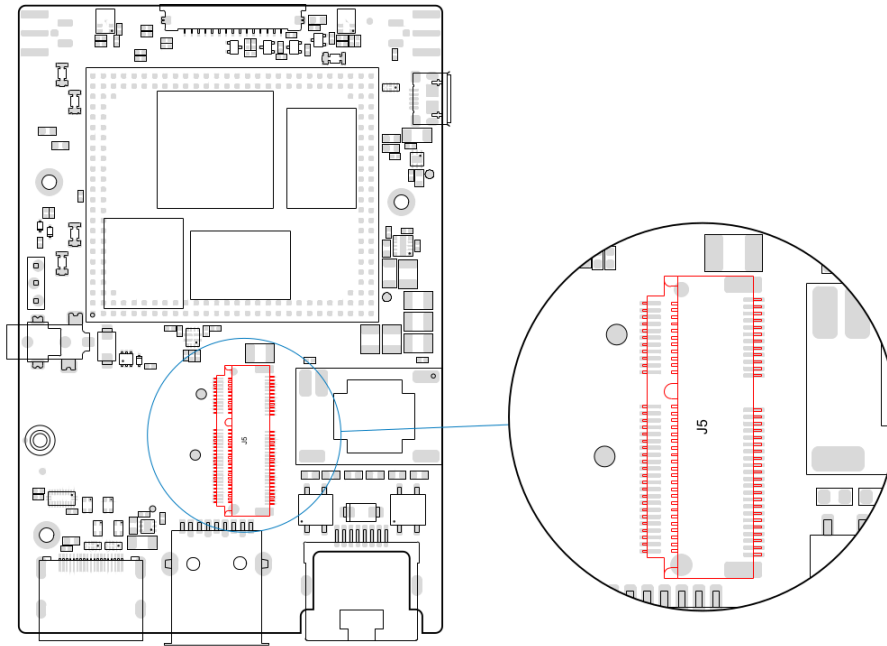

Figure 11: M.2 interface

## 5.6 Ethernet

The Grinn AstraEVB-1680 board integrates a Microchip KSZ9031RNXI Ethernet transceiver, enabling reliable 10/100/1000 Mbps Ethernet connectivity. This transceiver connects to the Grinn AstraSOM-1680 processor via an RGMII (Reduced Gigabit Media-Independent Interface), ensuring efficient, high-speed data transfer. The KSZ9031RNXI is designed for robust network performance, providing low latency and stable communication ideal for data-intensive applications. With its built-in Ethernet PHY, the board is ready for seamless network integration, making it a solid choice for projects requiring high-speed wired connectivity.

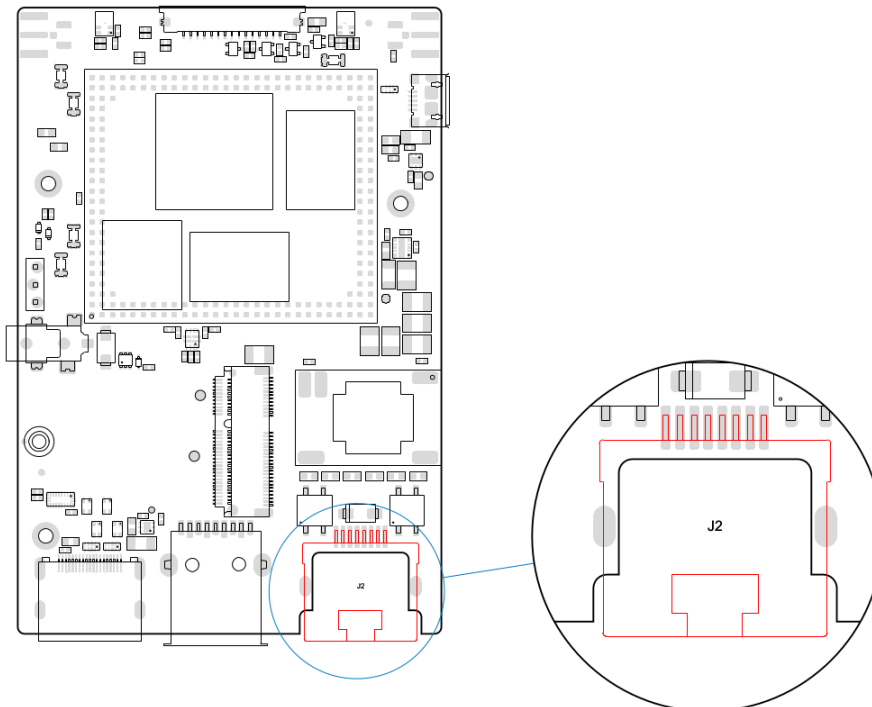

Figure 12: Ethernet connector

## 5.7 USB

The Grinn AstraEVB-1680 board is equipped with both a USB 2.0 OTG (On-The-Go) port and a USB 3.0 port, offering versatile connectivity options. The USB 2.0 OTG port allows the board to act as both a host and a device, enabling it to connect to a wide range of peripherals, such as keyboards, mice, or external storage. The USB 3.0 port provides faster data transfer speeds, making it ideal for high-bandwidth devices like external hard drives or high-definition cameras. This combination of USB ports ensures the board can handle various connectivity needs, from simple peripheral connections to high-performance data exchanges.

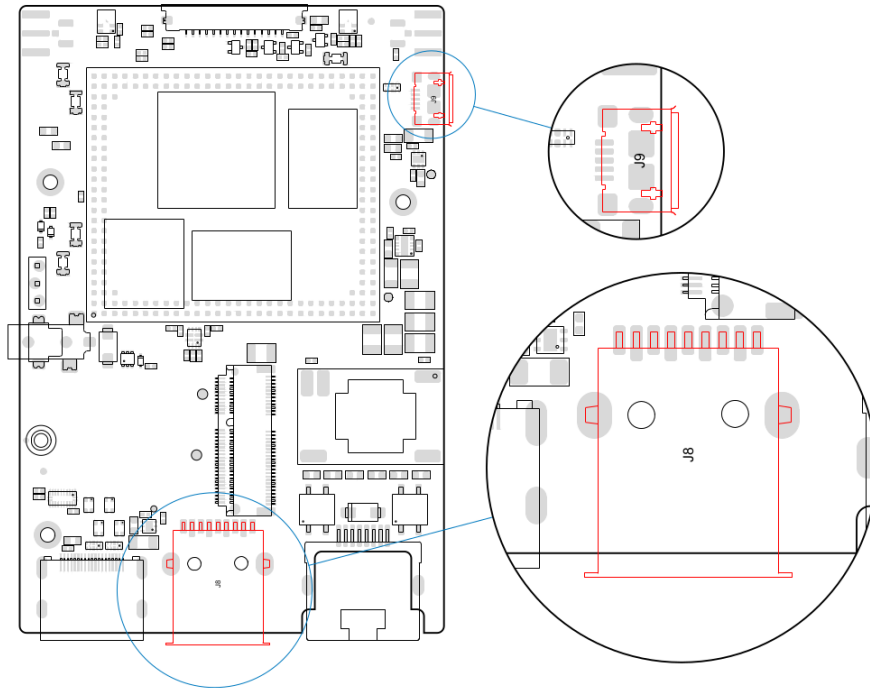

Figure 13: USB connectors

### 5.8 Radar

The Grinn AstraEVB-1680 board integrates an Aconeer A121 radar module, providing advanced sensing capabilities for applications such as motion detection, presence sensing, and distance measurement. This radar communicates with the Grinn AstraSOM-1680 processor over an SPI interface, enabling fast and efficient data transfer for real-time processing. The Aconeer radar offers low power consumption and high accuracy, making it ideal for compact and battery-powered devices. With its ability to detect objects and movements through obstacles, this radar enhances the board’s functionality for smart home systems, robotics, and security applications. The seamless integration of the radar sensor allows for easy implementation in a wide range of use cases.

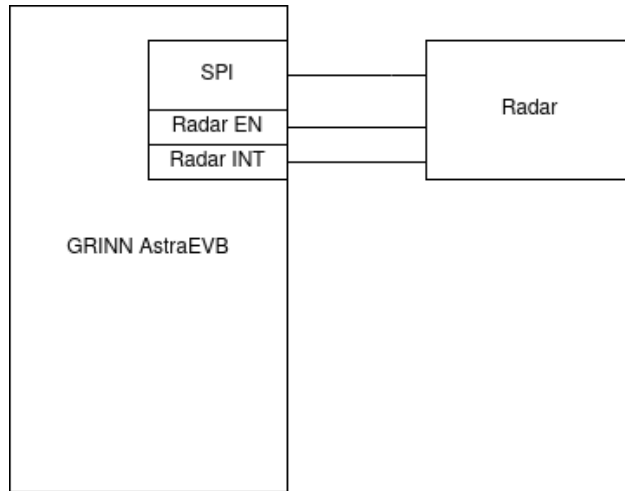

Figure 14: Radar connection

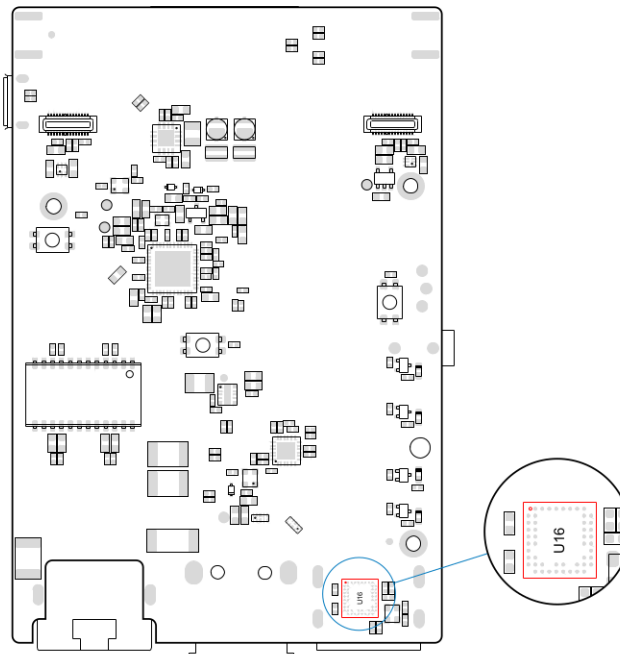

Figure 15: Radar

## 5.9 IR diodes

The Grinn AstraEVB-1680 board is equipped with two infrared (IR) diodes, powered by a Buck-Boost LED driver, ensuring efficient voltage regulation for the diodes. The power to the diodes is controlled through GPIO pins, allowing for precise control of the power usage. The Buck-Boost LED driver ensures consistent performance of the diodes, even with varying input voltages. With GPIO control, users can easily integrate the IR diodes into their projects while optimizing power consumption.

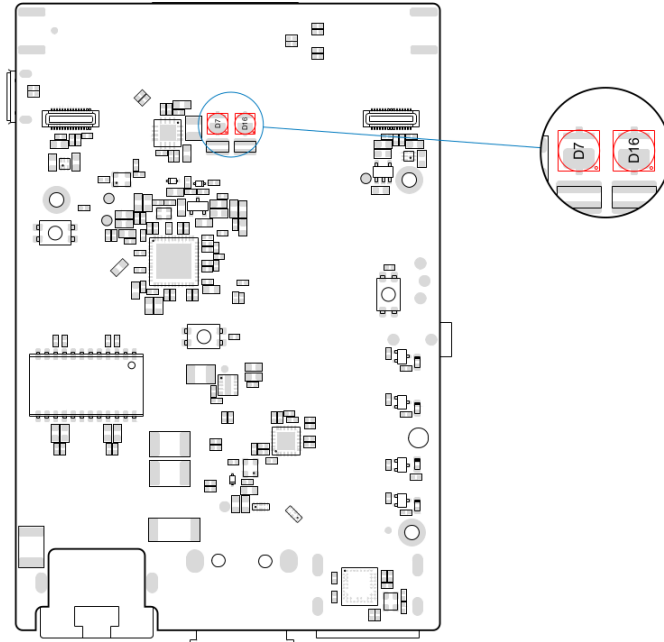

Figure 16: IR diodes



## 5.10 User-Configurable interfaces

The Grinn AstraEVB-1680 board has four general-purpose LEDs and a single user-configurable button. The LEDs can be programmed for various functions, such as status indication, activity monitoring, or custom signaling. The button serves as a versatile input, allowing users to trigger events, adjust settings, or implement specific actions in their applications. This combination of LEDs and a button provides a simple yet powerful interface for interaction, testing, and debugging. It offers flexibility to adapt to a wide range of use cases, enhancing the board's functionality.

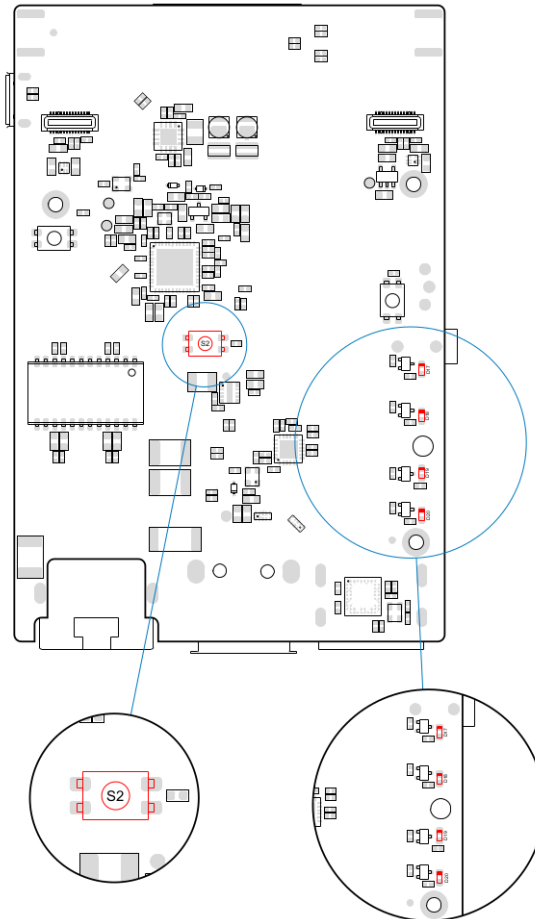

Figure 17: User-Configurable interfaces

## 6 Boot options

The Grinn AstraEVB-1680 board supports booting from its internal memory, providing a reliable and streamlined startup process. Upon power-up, the system initializes the hardware and executes the bootloader stored in the internal memory. This bootloader is responsible for loading the operating system or firmware, enabling the board to begin executing user-defined tasks.

### 6.1 Supported OS

The Grinn AstraEVB-1680 supports a custom Linux Yocto build. To obtain access to the Git repository, please contact [support@grinn-global.com](mailto:support@grinn-global.com).

### 6.2 Flashing

To flash the Grinn AstraEVB-1680, one needs a Linux or Windows host PC with `usb-tool`, a power adapter, and a micro USB cable.

Here's a high-level overview of the process:

- **Connect the Board:** Use the power adapter to power the board and connect the board to the host PC via the micro USB and debug port.
- **Launch the Flash script:** Navigate to the directory containing the image files and run the `run.sh` script.
- **Enter Flash Mode:** Follow these steps:
  - Open serial port terminal with speed 115200 baud.
  - Press and hold the BOOT (S3) button.
  - Press and release the RST (S1) button.
  - Release the BOOT button.
  - In the U-boot prompt write `l2emmc eMMCimg`

For a more detailed description of the process, please refer to the flashing instructions for the corresponding Synaptics Astra SL1680.

## 7 Electrical Characteristics

### 7.1 Absolute Maximum Ratings

Table 5: Grinn AstraEVB-1680 recommended ratings

	Minimum	Typical	Maximum	Unit
Supply voltage	6	12.0	12.5	V
Supply current		4		A
Operating ambient temperature	0	25	70	°C

Grinn sp. z o. o.  
Strzegomska 140a  
54-429 Wrocław  
Poland

www: <https://www.grinn-global.com>

office: [office@grinn-global.com](mailto:office@grinn-global.com)

phone: +48 71 716 40 99

products: <https://grinn-global.com/products>

technical support: [support@grinn-global.com](mailto:support@grinn-global.com)

Copyright © 2024 Grinn sp. z o. o.

All rights reserved. No part of this document may be photocopied or recorded on any electronic media without written permission of Grinn sp. z o. o.

The information contained in this documentation is subject to change without prior notice. We assume no liability for erroneous information or its consequences. Grinn sp. z o. o. reserves the right to change details in this publication without notice.

Grinn sp. z o. o. makes no representations or warranties with respect to the accuracy or completeness of the contents of this document and reserves the right to make changes to specifications and products descriptions at any time without notice. Grinn sp. z o. o. does not make any commitment to update the information contained herein.

Trademarks used from other companies refer exclusively to the products of those companies. Product and company names herein may be the trademarks of their respective owners.